

Multi-channel Display **ATT 300**

- Alternating display of 1 to 3 parameters
- 3 analog inputs : 3 x 4-20 mA or 3 x 0-10 V
- 1 RS 232 digital input for external transmitter (class 200 & 300)
- 1 RS 485 digital input/output (MODBUS protocol integrated)
- 22 pre-set units and 3 configurable units
- Configuration via software or remote control
- Multi-directional housing, made of ABS V-0 as per UL 94
- Large display 2.0" x 7.5"



Part number

To order, just add the codes to complete the part number.

Power supply
24 Vac/dc 230 Vac



Pre-set units

Air velocity	fpm m/s
Airflow	cfm L/s m ³ /h m ³ /s
Temperature	°F °C
Pressure	in H ₂ O PSI mbar Kpa mmHg Pa mmH ₂ O
Humidity	%RH g/kg (Hygro. absolue p) °F (Temp. de rosée Td) °C (Temp. de rosée Td) °F (Temp. humide Tw) °C (temp. humide Tw) KJ/Kg (Enthalpie l)

Housing dimensions

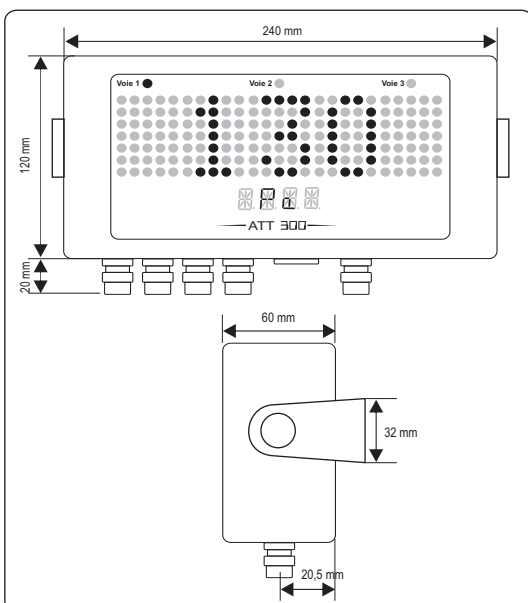

Display features

Display	electroluminescent alphanumeric (3.0" x 7.5") protection screen made of inactinic red PMMA
1 st line (measurement)	5 digits (dot matrix 5x7) \neq 2.0" x ℓ 7.5"
2 nd line (unit)	4 digits (14 segments) \neq 0.5" x ℓ 1.8"
Decimal position	configurable 0 / 0.0 / 0.00 / 0.000
Measurement value	from -9.999 to 99.999 and from -9999 to 99999
Accuracy	\pm 0.1% of the measurement \pm 1 digit
Number of channels	from 1 to 3 channels, alternatively (3 seconds)
Location of channels	with 3 red identified LED
Units available	22 pre-set units (see chart) 3 configurable units
Response time	< 1 sec.

Housing features

Housing	multi-directional made of ABS
Protection factor	IP 63
Fire-proof classification	V-0 as per UL 94
Dimensions	see drawing
Connection gland	Polyamide for cable of 0.3" max.
Weight	2.2 lbs

Technical specifications

Power supply	24 Vac/Vdc \pm 10% or 230 Vac \pm 10%, 50-60Hz
Galvanic isolation	between input and power supply
Analogue inputs	3 x 4-20 mA (4 wires) or 3 x 0-10 V
Consumption	5 VA
Electro-magnetical compatibility	EN61 326
Electrical connection	screw terminal block
RS 485 communication	digital : RTU Modbus protocol communication speed configurable from 2400 to 115200 Bauds
RS 232 communication	digital : ASCII, proprietary protocol
Working temperature	32 to 122°F
Storage temperature	14 to 158°F

* All accuracies indicated in this technical datasheet were stated in laboratory conditions, and can be guaranteed for measurements carried out in the same conditions, or carried out with calibration compensation.

Connection

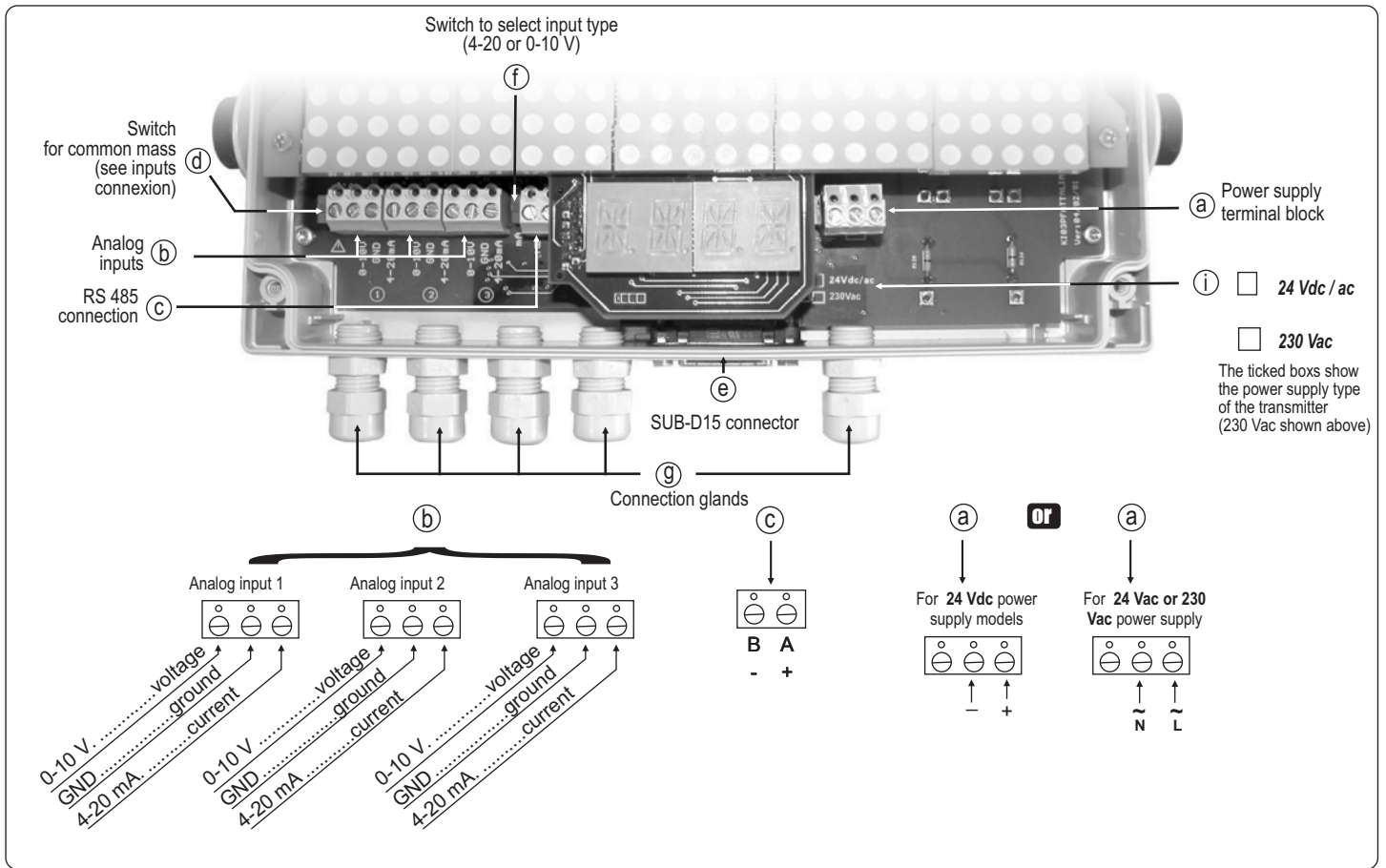

Electrical connections - as per NFC15-100 norm

⚠ This connection must be made by a qualified technician. When making the connection, the transmitter must not be energized. Before making the connection, you must first check the power supply which is indicated on the transmitter board (see ① on the connection drawing)

Power supply connection :

- For 24 Vdc power supply models :

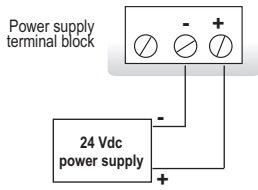

- For 24 Vac power supply models :

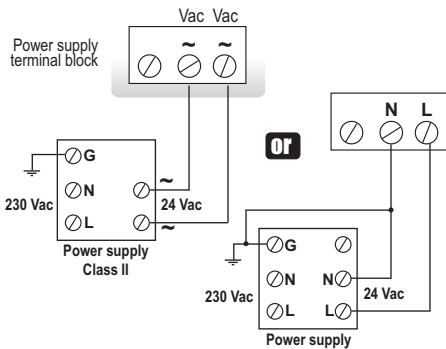

- For 230 Vac power supply models :

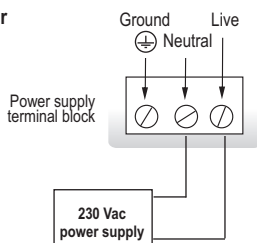

Inputs connection :

- current input 4-20 mA :

The 4-20 mA input switch ① must be located **down**.

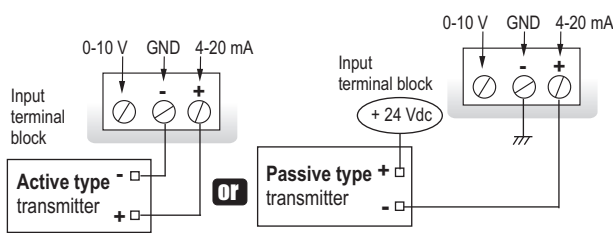

⚠ Special case (for passive type transmitter) :

If power supply is common to ATT and transmitter, you must locate the switch ① **UP**.

This switch enables to have the ground power supply common to the ATT and the passive type transmitter.

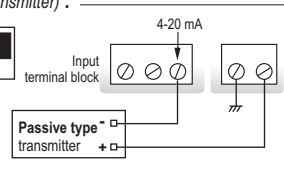

- 0-10 V voltage input :

The 0-10 V input switch ① must be located **UP**.

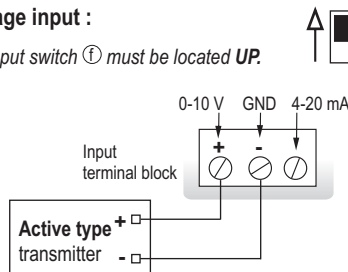

Connection of SUB-D15 RS 232 and RS 485 (see ⑥ on connection drawing)

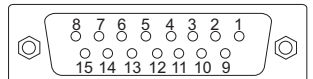

Pin #	Description
1	NC *
2	NC *
3	NC *
4	B - (RS 485)
5	A + (RS 485)
6	NC *
7	NC *
8	NC *
9	RX (RS 232)
10	NC *
11	TX (RS 232)
12	NC *
13	NC *
14	NC *
15	GND (RS 232)

⚠ CAUTION :
NC * --> DO NOT CONNECT

Analog / Digital inputs

ATT displays 1 to 3 parameters that can be measured via the following connections :

- **3 analog inputs :**
3 x 4-20 mA or 3 x 0-10 V
- **2 analog inputs and 1 digital input**
2 x 4-20 mA or 2 x 0-10 V and 1 parameter via RS 232* connection
- **1 analog input and 2 digital inputs**
1 x 4-20 mA or 1 x 0-10 V and 2 parameters via RS 232* connection

* parameter(s) from an external transmitter (Class 200 or 300) connected via RS 232 connection (proprietary protocol).



Digital communication

RS 232 communication



- Via the RS 232 connection, ATT 300 can display 1 to 2 parameters which are measured by other transmitters from Class 200 and 300.
- RS 232 communication also enable to configure the transmitter via LCC-300 software.
- RS 232 connection cable is available in 6', 16' or 32' (maximum) lengths.

RS 485 Modbus Protocol

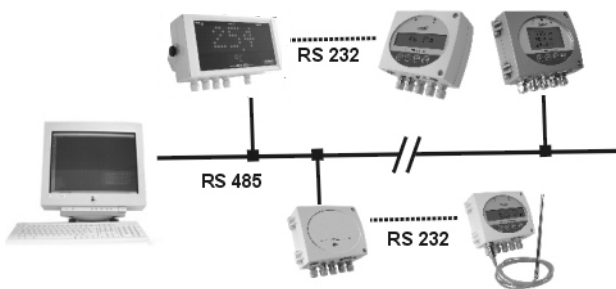

- ATT 300 display enables to have a network of transmitters/displays on a RS 485 Modbus system, or to integrate them in an existing network.
- When one or several transmitters from Class 200 or 300 are connected to ATT 300 display, all information displayed can be sent to BMS via RS 485, with only one address.
- RS485 digital communication is a 2-wire network on which transmitters are connected in parallel. They are connected to a PLC/BMS via the RTU Modbus communication system. In the same way as ATT configuration via remote control, Modbus system enable to configure at distance: activate/deactivate a channel, set the measuring ranges of each analog inputs.

- With RS 485 Modbus protocol, ATT 300 can receive and display measurements made by other transmitters via a PLC.

Configuration

You can configure all parameters (units, analog inputs, display channels) via the different methods shown below:

- **Via remote control (optional)**
For transmitters located in hard to reach positions. See configuration manual.
- **Via software (optional)**
User-friendly configuration. See LCC-300 user manual.
- **Via Modbus (optional)**
Configuration of all parameters from your PC, via the supervision or data acquisition software.

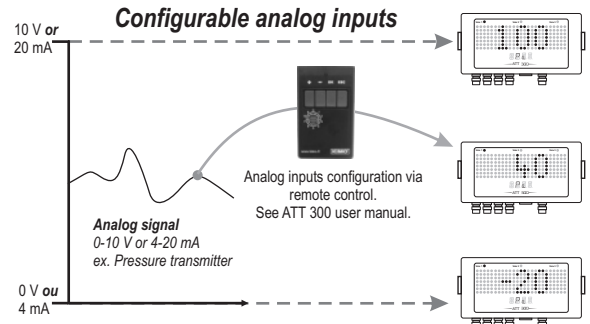

Mounting

- With the 2 screws, install the mounting bracket in horizontal position along a plane wall (see below dimensions / drilling drawing).
- Put the display inside the mounting bracket, with the 2 screws. Remove the screw covers located on the right and left side of housing, in order to have access to the 4 shutting screws.
- Make the electrical connection with the connection glands, with soft cable $\varnothing 0.3"$ maximum. Close the housing before powering on.

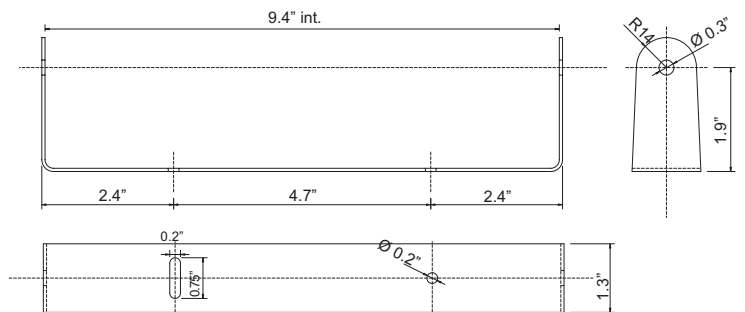

Maintenance

- Avoid aggressive solvents.

Options

- LCC 300 configuration software with RS 232 cable
- Configuration remote control.



E Instruments International LLC
172 Middletown Blvd. - Suite B201
Langhorne, PA 19047
Tel.: 215 750 1212
Fax.: 215 750 1399
email: info@E-Inst.com